

### Material

Body	Nickel Plated Brass
Seals	EPDM
O-Rings	EPDM
Spring	Stainless Steel

### Dimension

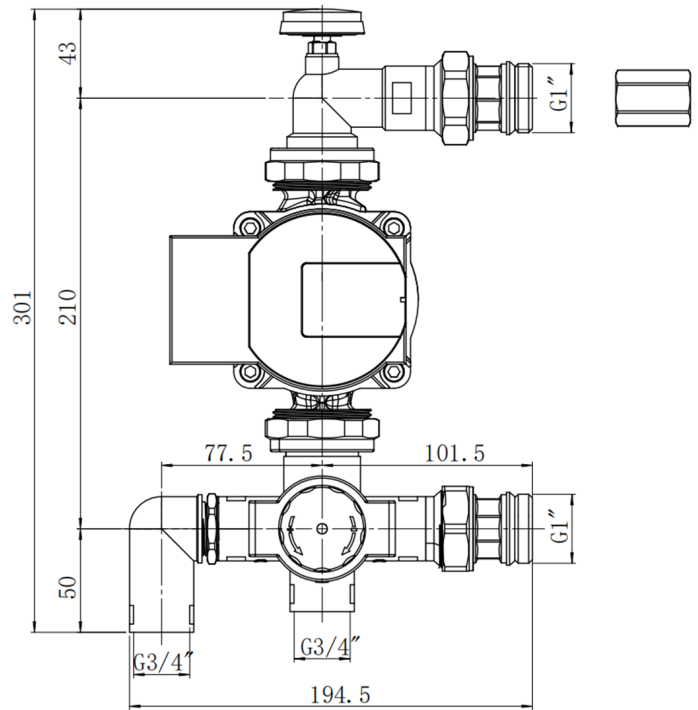

### Technical Specification

Hot temperature supply range	60°C - 85°C
Adjustable temperature range	35°C - 60°C
Maximum supply pressure	10 bar
Factory pre-set	45°C (Control knob is in the adjustable position)
Temperature stability	+/- 3°C
Kvs Value	2.24 m <sup>3</sup> /h
Connections	Mixing valve inlets 3/4 " FBSP Manifold connections 1 " MBSP

### Pressure Drop Graph

